

# Cleaning Air Box - 115 VAC

# Cleaning Air Box - 230 VAC

COMPRESSED AIR SUPPLY UNIT



a xylem brand



**Note**

For the most recent version of the manual, please visit [www.yisi.com](http://www.yisi.com).

**Contact**

YSI  
1725 Brannum Lane  
Yellow Springs, OH 45387 USA  
Tel: +1 937-767-7241  
800-765-4974  
Email: [environmental@ysi.com](mailto:environmental@ysi.com)  
Internet: [www.yisi.com](http://www.yisi.com)

**Copyright**

© 2013 Xylem Inc.

## Cleaning Air Box - Contents

<b>1</b>	<b>Overview</b>	<b>1-1</b>
1.1	Structure and function	1-1
<b>2</b>	<b>Safety</b>	<b>2-1</b>
2.1	Safety information	2-1
2.1.1	Safety information in the operating manual	2-1
2.1.2	Safety signs on the product	2-1
2.1.3	Further documents providing safety information	2-1
2.2	Safe operation	2-2
2.2.1	Authorized use	2-2
2.2.2	User qualification	2-2
2.2.3	Requirements for safe operation	2-2
2.2.4	Unauthorized use	2-2
<b>3</b>	<b>Installation</b>	<b>3-1</b>
3.1	Scope of delivery	3-1
3.2	Requirements of the measurement location	3-1
3.3	Safety requirements on the electrical installation	3-1
3.4	Mounting	3-2
3.5	Electrical connection	3-4
3.5.1	General installation instructions	3-4
3.5.2	Connecting the wires	3-5
3.6	Installing / retrofitting a check valve (option)	3-6
<b>4</b>	<b>Operation</b>	<b>4-1</b>
4.1	Operating modes	4-1
4.2	Actions against the formation of condensate and icing	4-2
<b>5</b>	<b>Maintenance and cleaning</b>	<b>5-1</b>
5.1	Maintenance	5-1
5.1.1	General maintenance instructions	5-1
5.1.2	Exchange of the pump membrane and valve plates	5-1
5.2	Cleaning	5-4
<b>6</b>	<b>Replacement parts and accessories</b>	<b>6-1</b>
<b>7</b>	<b>What to do if...</b>	<b>7-1</b>
<b>8</b>	<b>Contact Information</b>	<b>8-1</b>
8.1	Ordering & Technical Support	8-1
8.2	Service Information	8-1
<b>9</b>	<b>Technical data</b>	<b>9-1</b>



# 1 Overview

## 1.1 Structure and function

The Cleaning Air Box is used to clean sensors with compressed air. It is suitable to be used at the measuring location and can be installed outdoors (sun shield recommended). The integrated compressor (membrane pump) draws in air from outside through an intake air filter and presses it through the cleaning nozzles at the sensor. This cleans the sensor element.

The Cleaning Air Box operates at intervals. The pump is switched on and off with an external switch. A relay contact of the measuring system is used as the switch. The relay contact is configured and controlled for the cleaning function via the software of the measuring system.

### System requirements

Depending on the measuring system, the following is required:

- IQ SENSORNET System 182: A free relay contact in the Universal Transmitter DIQ/S 182.
- IQ SENSORNET System 2020 XT: A free relay contact in an MIQ/CR3 or MIQ/R6.

### Circuit diagram

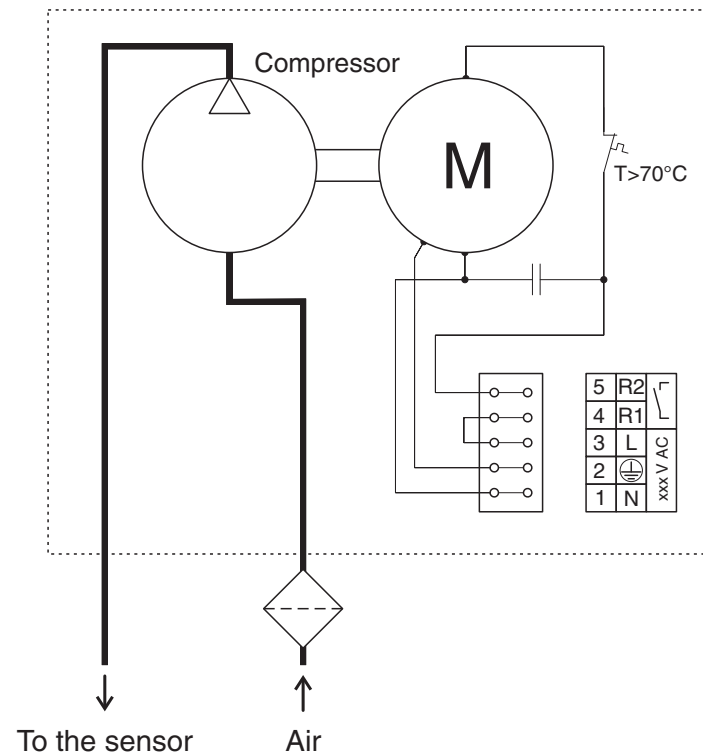

Fig. 1-1 Circuit diagram of the Cleaning Air Box

The following example shows the use of the Cleaning Air Box in an IQ SENSORNET System 182:

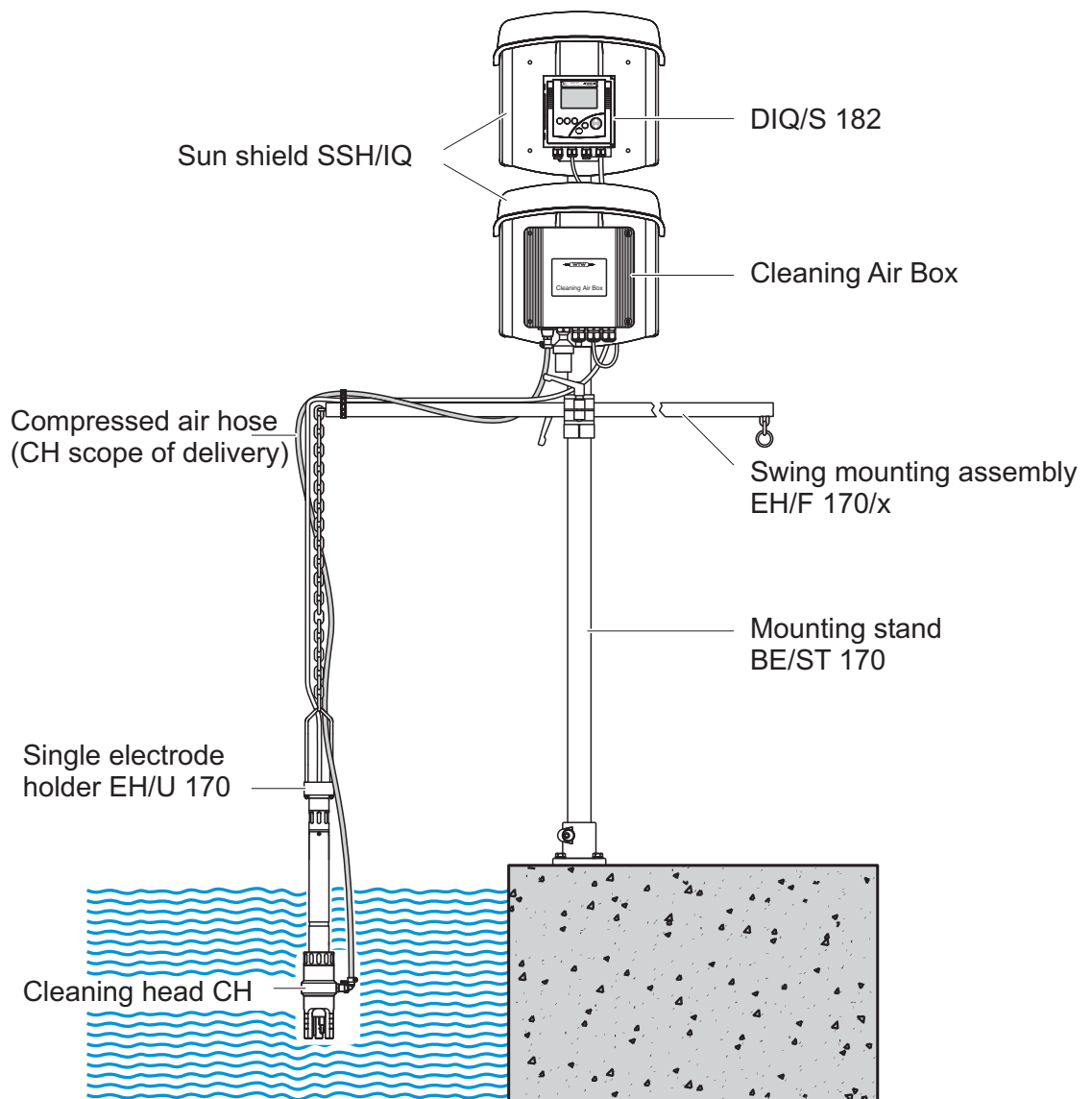

Fig. 1-2 Application example for the Cleaning Air Box

## 2 Safety

### 2.1 Safety information

#### 2.1.1 Safety information in the operating manual

This operating manual provides important information on the safe operation of the product. Read this operating manual thoroughly and make yourself familiar with the product before putting it into operation or working with it. The operating manual must be kept in the vicinity of the product so you can always find the information you need.

Important safety instructions are highlighted in this operating manual. They are indicated by the warning symbol (triangle) in the left column. The signal word (e.g. "Caution") indicates the level of danger:



#### **WARNING**

**indicates a possibly dangerous situation that can lead to serious (irreversible) injury or death if the safety instruction is not followed.**



#### **CAUTION**

**indicates a possibly dangerous situation that can lead to slight (reversible) injury if the safety instruction is not followed.**

#### **NOTE**

*indicates a possibly dangerous situation where goods might be damaged if the actions mentioned are not taken.*

#### 2.1.2 Safety signs on the product

Note all labels, information signs and safety symbols on the product. A warning symbol (triangle) without text refers to safety information in this operating manual.

#### 2.1.3 Further documents providing safety information

The following documents provide additional information, which you should observe for your safety when working with the measuring system:

- Operating manuals of other components of the IQ SENSORNET system (power pack, controller, accessories)

## 2.2 Safe operation

### 2.2.1 Authorized use

Authorized use of the Cleaning Air Box is the supply with compressed air from compressed air-driven sensor cleaning systems. Only the operation and running of the product according to the instructions and technical specifications given in this operating manual is authorized (see chapter 9 TECHNICAL DATA). Any other use is considered unauthorized.

### 2.2.2 User qualification

**Installation** Installation may only be carried out by a trained electrical engineering technician.

**Maintenance** All maintenance activities that require the opening of the enclosure may only be carried out by a trained electrical engineering technician.

### 2.2.3 Requirements for safe operation

Note the following points for safe operation:

- The product may only be operated according to the authorized use specified above.
- The product may only be supplied with power by the energy sources mentioned in this operating manual.
- The product may only be operated under the environmental conditions mentioned in this operating manual.
- The product may only be opened if this is explicitly described in the present operating manual (example: Changing the intake air filter).

### 2.2.4 Unauthorized use

The product must not be put into operation if:

- it is visibly damaged (e.g. after being transported)
- it was stored under adverse conditions for a lengthy period of time (storing conditions, see chapter 9 TECHNICAL DATA).



## 3 Installation

### 3.1 Scope of delivery

The following parts are included in the scope of delivery of the Cleaning Air Box:

- Cleaning Air Box
- Accessory set, including
  - Intake air filter
  - 4 x screws M5x16
  - Fitting for compressed air hose
  - Hose clip
- Operating manual.

### 3.2 Requirements of the measurement location



#### **WARNING**

**The Cleaning Air Box is not suitable for operation in a potentially explosive environment.**

#### **Ambient conditions**

If the Cleaning Air Box is installed outside it should be protected by a sun shield against the effects of the weather (snow, ice and direct solar radiation). The measurement location must meet the environmental conditions specified in chapter 9 TECHNICAL DATA.

### 3.3 Safety requirements on the electrical installation

Electrical equipment (e.g. motors, contactors, cables, lines, relays) must meet the following requirements:

- Conformity with national regulations (e.g. NEC, VDE and IEC)
- Suitability for the electrical conditions at the installation site
  - Maximum operating voltage
  - Maximum operating current
- Suitability for the environmental conditions at the installation site
  - Temperature resistance (minimum and maximum temperature)
  - Stability against UV light when used outdoors
  - Protection against water and dust (Nema or IP protection class).
- Suitable fusing of the electrical circuit
  - Overcurrent fuses (in accordance with the technical data of the device input or output)
  - Overvoltage class II surge limiters
- Suitable disconnecting device (e. g. switch or circuit breaker) for the mains supply of permanently mounted equipment with separate mains connection

- in compliance with the following regulations
  - IEC 60947-1
  - IEC 60947-3
- in the vicinity of the equipment (recommendation)
- Flame-resistant (cables and lines), in compliance with the following regulations
  - UL 2556 VW-1 (for USA, Canada)
  - IEC 60332-1-2 (outside of USA, Canada)

### 3.4 Mounting

#### Mounting the sun shield

Suitable sun shields are the SSH/IQ (single) and SD/M 170-D (double).



Ordering information on the sun shields is given in chapter 6 REPLACEMENT PARTS AND ACCESSORIES.

Mount the Cleaning Air Box on the sun shield as follows.

1	Open the lid of the Cleaning Air Box.
2	Mount the Cleaning Air Box on the sun shield by tightening the supplied M5 screws at the corners.

**Connecting the  
compressed air  
hose and intake  
air filter**

Fig. 3-1 Connecting the compressed air hose and intake air filter

To connect the compressed air hose use the supplied fitting (pos. 1 in Fig. 3-1) and secure the compressed air hose with the supplied hose clip (pos. 2). Screw the intake air filter (pos. 3) into the filter socket (pos. 4) by hand.

**NOTE**

*The cleaning nozzles at the sensor may only be immersed up to 1.5 m. When installing the compressed air hose make sure that no water possibly remaining in the hose can enter the Cleaning Air Box.*

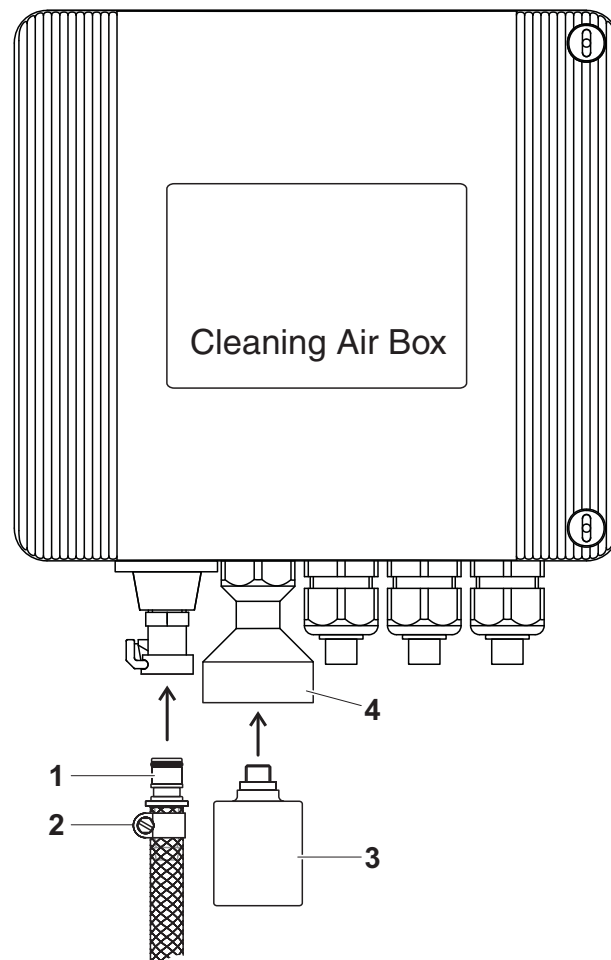
### 3.5 Electrical connection

#### 3.5.1 General installation instructions



#### **WARNING**

If the power supply is connected incorrectly, it may represent a danger to life from electric shock. Pay attention to the following points during installation:

- The Cleaning Air Box may only be connected by a trained electrician.
- The power supply must fulfill the specifications given on the nameplate and in chapter 9 TECHNICAL DATA.
- The Cleaning Air Box may only be connected when it is voltage-free.
- An electrical interrupt facility (e.g. switch) for the Cleaning Air Box must be available on site (see section 3.3 SAFETY REQUIREMENTS ON THE ELECTRICAL INSTALLATION).
- The line power supply must only be switched on while the enclosure lid is closed.

#### **Control line**

As the control line, use a two-wire cable without shielding. The cable must meet the requirements according to section 3.3 SAFETY REQUIREMENTS ON THE ELECTRICAL INSTALLATION and chapter 9 TECHNICAL DATA.

#### **NOTE**

*No external voltages must be fed into the control line. With the IQ SENSORNET System 182, the control cycle must not be connected to the auxiliary supply output of the Universal Transmitter DIQ/S 182.*

#### **Control relays**

Before putting the Cleaning Air Box into operation, make sure that the nominal voltage of the Cleaning Air Box (see chapter 9 TECHNICAL DATA) does not exceed the maximum switching voltage of the relay (see technical data of the relay).

#### **NOTE**

*If the nominal voltage of the Cleaning Air Box exceeds the maximum switching voltage of the relay (such as with the relay of the MIQ/VIS), the relay will be destroyed.*

#### **General installation notes**

Observe the following points when attaching connecting wires to the terminal strip:

- Shorten all the wires to be used to the length required for the installation
- Always fit all the ends of the wires with wire end sleeves before connecting them to the terminal strip
- Any wires that are not used and project into the housing must be cut off as closely as possible to the cable gland.
- Close all unused cable glands with blind plugs.

### 3.5.2 Connecting the wires

**Materials required**

- Wire end sleeves, suitable for the connecting wires, with suitable crimping tool

**Tools**

- Cable stripping knife
- Wire stripper
- Small screw driver

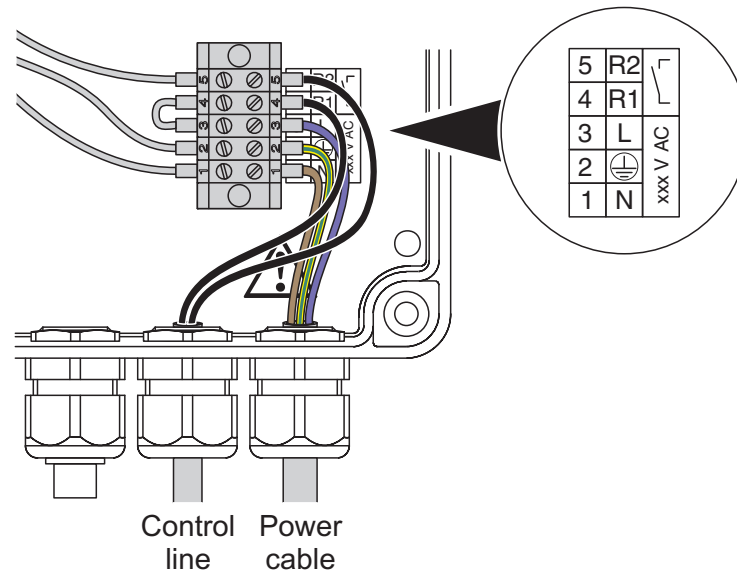

Fig. 3-2 Electrical connection

3	Open the enclosure of the Cleaning Air Box.
4	Feed the power cable into the enclosure through the right-hand cable gland.
5	Feed the control line into the enclosure through the second cable gland from the right.
6	Connect all wires to the terminal strip. While doing so, pay attention to the specifications on the label located on the right side of the terminal strip.
7	Close the enclosure of the Cleaning Air Box.

### 3.6 Installing / retrofitting a check valve (option)

The BPV check valve (see chapter 6 REPLACEMENT PARTS AND ACCESSORIES) is available as an accessory. It prevents the test sample from rising through the cleaning nozzles into the hose system due to hydrostatic pressure. It is especially recommended with immersion depths of more than 1 m and can be retrofitted at any time.

The check valve is mounted into the length of tubing on the pressure side in the enclosure of the Cleaning Air Box. To do so, proceed as follows:



**WARNING**

While the Cleaning Air Box is operating, there are the following dangers inside it:

- Danger to life due to voltage-carrying electrical lines.
- Risk of injury for the fingers and risk of hair and loose clothing being drawn in at the blower wheel of the pump.

Before opening the enclosure, disconnect the Cleaning Air Box from the power supply and secure it against being switched on inadvertently.

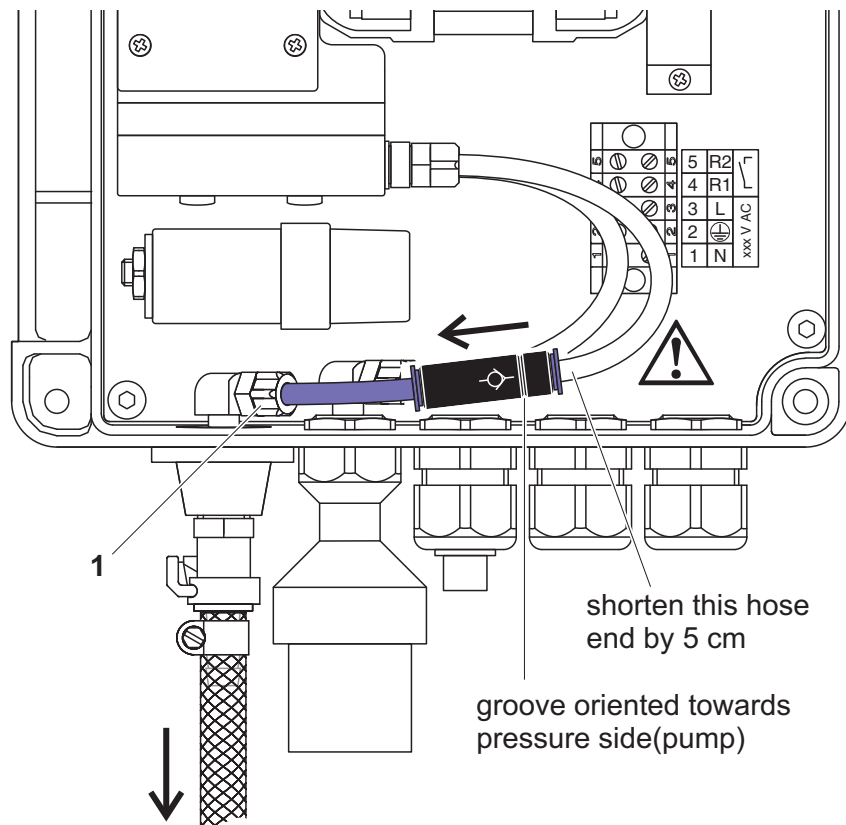

Fig. 3-3 Check valve

1	Open the hose connection at the compressed air outlet. To do so, open the coupling ring (pos. 1 in Fig. 3-3) and pull off the hose.
2	Shorten the bared hose end by 5 cm.

---

3	Insert the shortened hose end into the free hose coupling at the check valve as far as it will go.
4	Insert the free hose end of the check valve into the connection at the compressed air outlet as far as it will go and tighten the coupling ring (pos. 1) by hand.





## 4 Operation

### 4.1 Operating modes

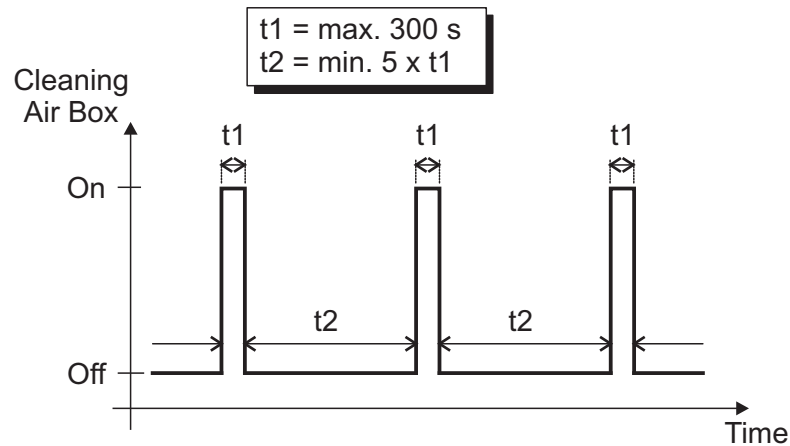

Fig. 4-1 Pulse operation with the Cleaning Air Box

The Cleaning Air Box is designed for discontinuous operation. After a certain pump time  $t_1$  ("cleaning duration") a stoppage  $t_2$  that lasts at least five times as long as the cleaning duration must follow (for example 2 min On, 10 min Off). The maximum allowed cleaning duration is 300 s.

#### **NOTE**

*The Cleaning Air Box is not suitable for continuous operation. Continuous operation can lead to an automatic switch-off due to excessive heat.*

#### **Control relays**

All IQ SENSORNET relays can be configured for activation of the Cleaning Air Box. The maximum allowed cleaning duration for the Cleaning Air Box is automatically observed with these instruments. More detailed information is given in the instruments' operating manuals.

#### **NOTE**

*The control relay should work exclusively as a closer to avoid continuous operation of the Cleaning Air Box in the case of a power failure at the measuring system. All relays that can be configured for cleaning purposes of YSI instruments are permanently set to "Closer".*

## 4.2 Actions against the formation of condensate and icing

During very damp weather, moisture can condensate, gather and, at temperatures below 0°C, freeze in the hose system and pump. This can possibly affect the pumping capacity.

With outside temperatures around and below the freezing point, check the hose system for water or ice in the lines.

To prevent the icing of the pump, you can shorten the stoppage and/or extend the cleaning duration. Due to the lower ratio of stoppages and cleaning durations, the generation of heat during operation is often enough to prevent the formation of ice in the pump.

### **NOTE**

*When installing the compressed air hose make sure that no water possibly remaining in the hose can enter the Cleaning Air Box.*

## 5 Maintenance and cleaning

### 5.1 Maintenance

#### 5.1.1 General maintenance instructions



#### WARNING

While the Cleaning Air Box is operating, there are the following dangers inside it:

- Danger to life due to voltage-carrying electrical lines.
- Risk of injury for the fingers and risk of hair and loose clothing being drawn in at the blower wheel of the pump.

Before opening the enclosure, disconnect the Cleaning Air Box from the power supply and secure it against being switched on inadvertently.

#### Maintenance plan

Maintenance activity	Recommended interval
Visual check of all hoses and hose connections	monthly
Exchange of the intake air filter	yearly
Exchange of the pump membrane and valve plates (see section 5.1.2)	every 5000 operating hours or every 5 years



Depending on environmental conditions (e.g. dust in the air, high temperatures), the maintenance intervals can vary.

#### 5.1.2 Exchange of the pump membrane and valve plates



This exchange can be carried out without problems by technically versed laypersons. If you wish service personnel to carry out the exchange, please contact YSI.



Ordering information on pump spare parts is given in chapter 6 REPLACEMENT PARTS AND ACCESSORIES.

#### Dismantling the mounting plate with pump

1	Open the enclosure of the Cleaning Air Box.
2	Disconnect all wires of the power cable and control line from the terminal strip.
3	Remove the two blue hoses from the pump head. To do so, loosen the blue coupling rings and pull off the hoses.

- 4 | Unscrew the mounting plate from the enclosure (4 hexagon socket head screws in the corners) and remove it completely with all mounted components.
- 5 | Remove the capacitor by undoing the nut at the mounting bracket. Do not disconnect the wiring!

**Exchanging parts**

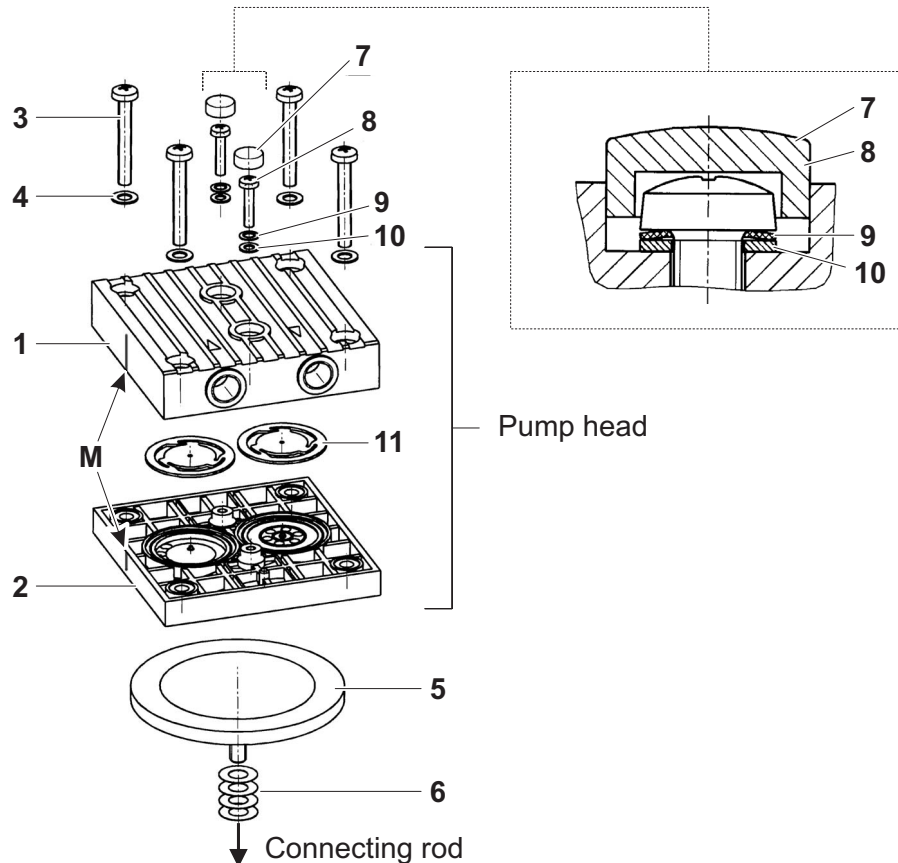

Fig. 5-1 Pump head

- 6 | Mark the position of the ribbed plate (pos. 1) and intermediate plate (pos. 2) by a drawing line with a felt-tip marker (M). This helps to avoid incorrect assembly later.
- 7 | Undo the 4 screws (pos. 3), remove the washers (pos. 4) and remove the entire pump head from the pump housing.
- 8 | Turn the fan to bring the membrane (pos. 5) to top dead center. Lift the edge of the membrane and, gripping it on opposite sides, unscrew it by turning anti-clockwise.
- 9 | Take the spacer(s) (pos. 6) of the threaded bolt of the membrane and screw them on the new membrane.
- 10 | Check that all parts are free from dirt and clean them with a cloth or blow them out with compressed air if necessary.

11	Turn the fan until the connecting rod is at top dead center. Then screw the new membrane with the spacer(s) on the connecting rod (clockwise) and tighten it by hand.
12	Separate the ribbed plate and intermediate plate. To do so, remove the screw caps (pos. 7) using a small screw driver, undo the screws (pos. 8), and remove the disk springs (pos. 9) and washers (pos. 10).
13	Remove the valve plates (pos. 11) from the intermediate plate.
14	Check that the valve seats, intermediate plate and ribbed plate are free from dirt. Replace them if they are deformed, scratched or corroded. Contact YSI in this case.
15	Insert the new valve plates in the valve seats of the intermediate plate. The valve plates for the pressure and intake side are identical. Check that the valve plates are not deformed by moving them gently sideways in their seats.
16	Place the ribbed plate on the intermediate plate in the position indicated by the felt-tip line marking (M). Check that the ribbed plate is centered by moving it gently sideways.
17	Screw together the ribbed plate and intermediate plate. For correct orientation of disk springs (pos. 9) see detail drawing. Torque: 2.5 Nm. Then install the screw caps (pos. 7) on the screw heads.
18	Turn the fan until the membrane is at top dead center.
19	Place the pump head on the housing with the correct orientation. Then tighten the screws (pos. 3) with the washers (pos. 4) gently, evenly and diagonally.
20	Turn the fan to check that the pump rotates freely. Turn the fan again to bring the membrane to top dead center and tighten the screws by hand diagonally (torque 3.5 Nm).

### Installing the mounting plate with pump

21	Screw the capacitor on the mounting bracket. Make sure the nut sits tightly and the cable routing is correct.
22	Insert the mounting plate with the mounted components in the housing and fix it at the corners with the four hexagon socket head screws.
23	Connect the two blue hoses to the pump head (pressure side at the front!).
24	Connect the power cable and control line to the terminal strip. While doing so, pay attention to the specifications on the label located on the right side of the terminal strip.
25	Close the enclosure of the Cleaning Air Box.

## 5.2 Cleaning

Clean components mounted in the open of gross contamination as necessary. We recommend to clean the worst of the dirt on the enclosure and the area around it each time before opening in order to prevent gross contamination from entering the open enclosure.

To clean the module, wipe the enclosure surfaces with a damp, lint-free cloth. If compressed air is available on site, blow off the worst of the dirt beforehand. Keep the housing closed while doing so.

**NOTE**

*Do not clean the Cleaning Air Box with a pressure washer.*

## 6 Replacement parts and accessories

<b>Description</b>	<b>Model</b>	<b>Order no.</b>
Intake air filter	AF/Cleaning Air Box	480 026Y
Check valve	BPV	480 029Y
Maintenance set, comprising replacement pump membrane and valve disks	RM/Cleaning Air Box	480 027Y





## 7 What to do if...

### Pump does not work

Cause	Remedy
– Loose cable	– Check wiring
– Cleaning relay does not switch	– Check/correct the settings of the measuring system
– With heavy frost: Formation of ice in the pump	– Warm up the Cleaning Air Box – For future operation, lower the ratio between stoppage and cleaning duration (see section 4.2)

### Cleaning is stopped prematurely

Cause	Remedy
– Excessive heat. Temperature fuse has interrupted the circuit (T>70 °C).	– Let the Cleaning Air Box cool down. The temperature fuse restores the circuit again automatically. – In the case of frequent failure, shade the Cleaning Air Box better or increase the ratio between stoppage and cleaning duration for future operation.

### Imperfect cleaning result

Cause	Remedy
– Water column in compressed air hose	– Check the hose system for leakiness and seal it – Reduce the depth of immersion of the sensor – If necessary, install a check valve (see section 3.6).
– Dirt at the cleaning nozzles and in the compressed air line	– Clean the cleaning nozzles and compressed air line – Install a check valve, especially with great depths of immersion (see section 3.6).
– Intake air filter dirty	– Replace intake air filter
– With heavy frost: Formation of ice in the compressed air line	– Deice the compressed air line – For future operation, lower the ratio between stoppage and cleaning duration (see section 4.2)



## 8 Contact Information

### 8.1 Ordering & Technical Support

Telephone: (800) 897-4151  
(937) 767-7241  
Monday through Friday, 8:00 AM to 5:00 PM ET

Fax: (937) 767-1058

Email: [environmental@ysi.com](mailto:environmental@ysi.com)

Mail: YSI Incorporated  
1725 Brannum Lane  
Yellow Springs, OH 45387  
USA

Internet: [www.ysi.com](http://www.ysi.com)

When placing an order please have the following information available:

YSI account number (if available)	Name and Phone Number
Model number or brief description	Billing and shipping address
Quantity	Purchase Order or Credit Card

### 8.2 Service Information

YSI has authorized service centers throughout the United States and Internationally. For the nearest service center information, please visit [www.ysi.com](http://www.ysi.com) and click 'Support' or contact YSI Technical Support directly at 800-897-4151.

When returning a product for service, include the Product Return form with cleaning certification. The form must be completely filled out for an YSI Service Center to accept the instrument for service. The Product Return form may be downloaded at [www.ysi.com](http://www.ysi.com) and clicking on the 'Support' tab.



## 9 Technical data

### Dimensions

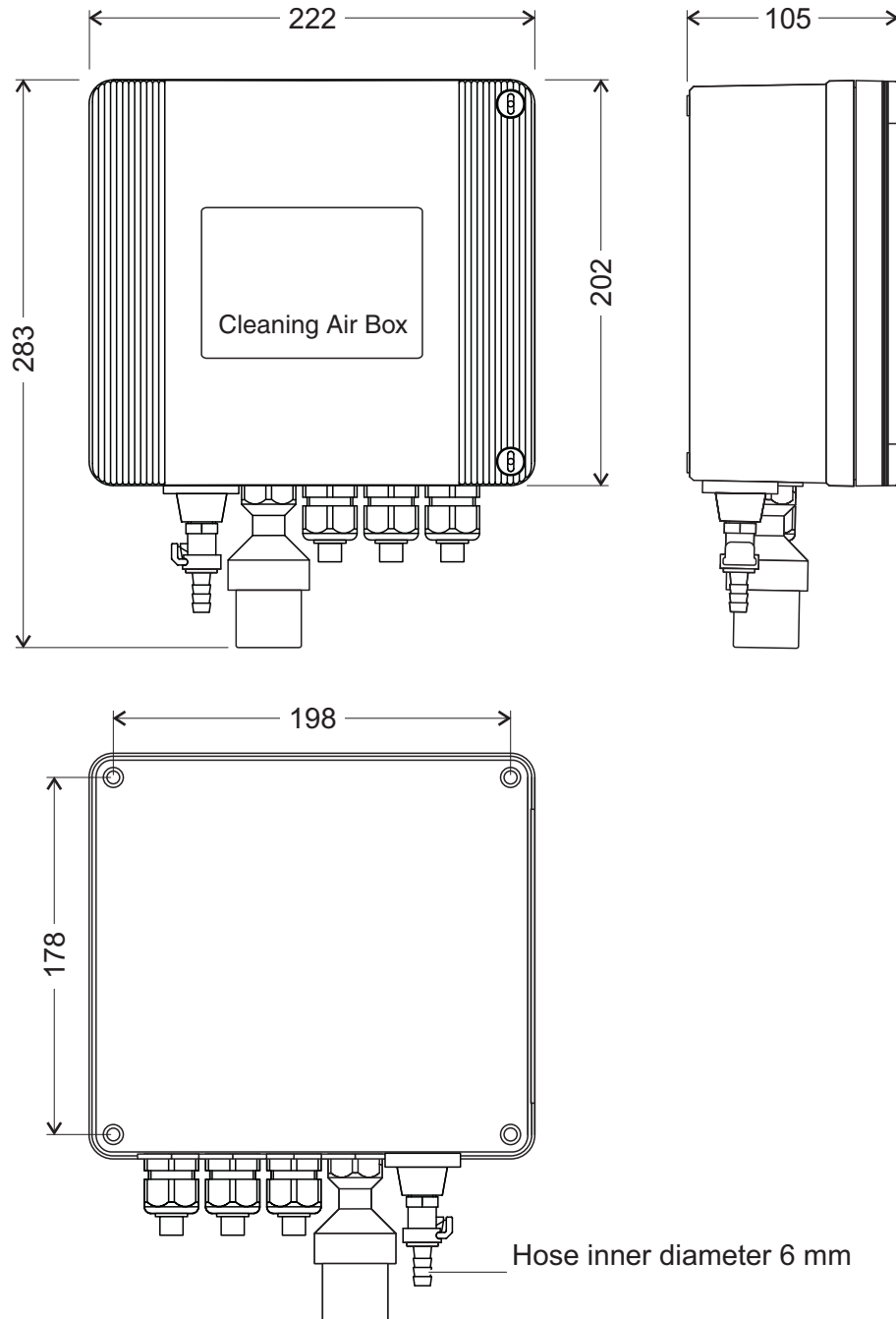
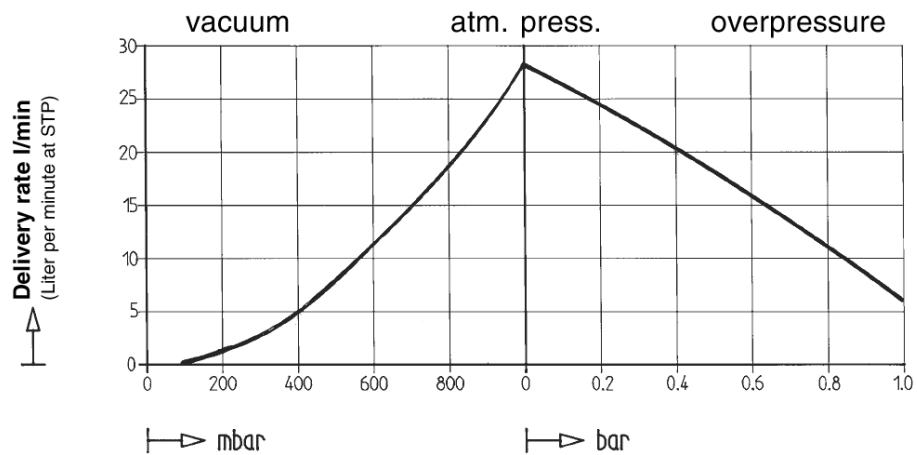

Fig. 9-1 Dimension drawing of the Cleaning Air Box (dimensions in mm)

### Test certificates

- CE
- cETLus (Cleaning Air Box - 115 VAC only)

<b>Delivery rate</b>	Maximum delivery rate	28 NL/min (Liter per minute at STP)
	Maximum operating pressure at the pump outlet	10 <sup>5</sup> Pa (1 bar) over pressure
	Maximum depth of immersion of the cleaning nozzles at the sensor	1.5 m



<b>Operation</b>	Operating mode	Pulse/Break operation (see section 4.1)
	Pulse/Break ratio	max. 1/5
	Maximum pulse duration or pumping time	300 s

**NOTE**

The Cleaning Air Box is not suitable for continuous operation.

<b>Mechanical structure</b>	Housing material	Polycarbonate with 20 % glass fiber
	Weight	approx. 3.6 kg
	Type of protection	<ul style="list-style-type: none"> <li>– IP 66</li> <li>– corresponds to NEMA 4X</li> </ul> The Cleaning Air Box is not suitable for Conduit Connection

<b>Ambient conditions</b>	<b>Temperature</b>	
	Operation	- 20 °C ... + 55 °C (- 4 ... 131 °F), Restricted operation under 0 °C under certain operating conditions only
	Storage	- 25 °C ... + 65 °C (- 13 ... 149 °F)
	<b>Relative humidity</b>	
	Yearly average	≤ 90 %
	Dew formation	Possible
	Site altitude	Max. 2000 m above sea level
<b>Electrical data</b>	Requirements of the power supply	Nominal voltage: 230 V AC ± 10 % / 50 Hz or 115 V AC ± 10 % / 60 Hz  Line power connection: 3-pin, N/L /PE  Cable cross-section: Europe: 1.5 ... 4.0 mm <sup>2</sup> USA: AWG 14 ... 12  Fuse rating on the operator side: max. 16 A  Temperature resistance of the cable at least 80 °C
	Protective class	I
	Overvoltage category	II
	Power consumption	Maximum approx. 100 W

**Electrical connections**

Terminal strip inside the enclosure:

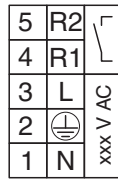

**Connection terminals**

Terminal type	Screw-type terminal strip, accessible by raising the lid
Terminal ranges	Solid wires:           0.2 ... 4.0 mm <sup>2</sup> AWG 24 ... 12 Flexible wires:       0.2 ... 2.5 mm <sup>2</sup>
Cable feeds	3 cable glands PG 13.5 at the lower side of the enclosure
Requirements of the control line	<ul style="list-style-type: none"> <li>– Two-core, unshielded</li> <li>– Cable cross-section at least 1.5 ... 4.0 mm<sup>2</sup> (AWG 14 ... 12)</li> <li>– Allowed operational voltage at least 300 V AC</li> <li>– Temperature resistance of the cable at least 80 °C</li> </ul>

**EMC product and system characteristics**

EN 61326	EMC requirements for electrical resources for control technology and laboratory use <ul style="list-style-type: none"> <li>– Interference immunity according to EN 61326/A1 table A.1</li> <li>– Resources for industrial areas, intended for indispensable operation</li> <li>– Interference emission limits for resources of class B</li> </ul>
System lightning protection	Extended protective characteristics as opposed to EN 61326/A1 table A.1
FCC, class A	

**Instrument safety**

Applicable norms	<ul style="list-style-type: none"> <li>– EN 61010-1</li> <li>– UL 61010-1</li> <li>– CAN/CSA C22.2 No. 61010-1</li> </ul>
------------------	---

The Cleaning Air Box meets the requirements according to article 3(3) of directive 97/23/EC ("pressure equipment directive").





# Xylem |'zīləm|

- 1) The tissue in plants that brings water upward from the roots;
- 2) a leading global water technology company.

We're 12,500 people unified in a common purpose: creating innovative solutions to meet our world's water needs. Developing new technologies that will improve the way water is used, conserved, and re-used in the future is central to our work. We move, treat, analyze, and return water to the environment, and we help people use water efficiently, in their homes, buildings, factories and farms. In more than 150 countries, we have strong, long-standing relationships with customers who know us for our powerful combination of leading product brands and applications expertise, backed by a legacy of innovation.

**For more information on how Xylem can help you, go to [www.xylem.com](http://www.xylem.com)**



a xylem brand

YSI  
1725 Brannum Lane  
Yellow Springs, OH 45387  
Tel: +1 937-767-7241; 800-765-4974  
Fax: +1 937-767-1058  
Email: [environmental@ysi.com](mailto:environmental@ysi.com)  
Web: [www.ysi.com](http://www.ysi.com)

©Xylem Inc